

Haier

Heat pump Water Heater Operation and Installation Manual



Model

HP200S1

HP300S1

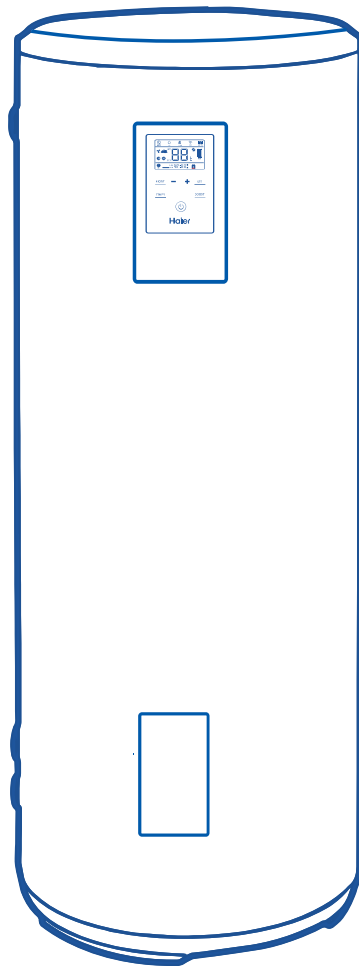
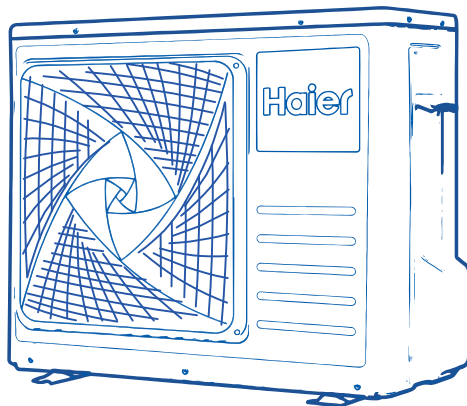

Please read this manual carefully prior to your use of this water heater.
The appearance of the water heater given in this manual is for reference only.

Contents

1. Safety instructions	3
2. Instructions on transportation and storage.....	6
3. Functionings & principles	6
4. Technical parameters	7
5. Description of parts and components	8
6. Installation introduction	11
7. Operation and functions	24
8. Checking and maintenance	28
9. Faults and protection	29
10. Product Fiche	30
11. Warranty certificate	31

Dear users of Haier,

Thank you for choosing Haier products.

Please read this manual carefully and follow the operation and safety instruction to ensure best installation and utilization of the product.





Product safety statement:







1. The appliance is not to be used by persons (including children) with reduced physical, sensory or mental capabilities, or lack of experience and knowledge, unless they have been given supervision or instruction. Children being supervised not to play with the appliance. Cleaning and user maintenance shall not be made by children without supervision.
2. Children shall be closely supervised to make sure they stay away from this product.
3. The method of installing safety valve please refer to Page 19.
4. The water may drip from the discharge pipe of the pressure relief device and this pipe must be left open to the atmosphere.
5. The water heater is to be drained according to the instructions specified on page 28.

Safety instructions (to be followed at any time)

Interpretation of marks and symbols

Failure to respect these instructions may lead to serious malfunctions of the device and to risks for the user

	<p>Instructions with this warning mark shall be strictly followed during operation. They relate to product and body safety of users.</p>
	<p>Information provided with this banning mark relates to activities that are definitely forbidden. Otherwise the machine may be damaged or users may risk personal danger.</p>

  <p>The water heater shall be installed in strict accordance with local wiring regulations, and equipped with power supply with a ground line. Please ensure an effective ground connection.</p>	 <p>Ground line and zero line of the power supply shall not be connected together. The ground line shall not be connected to pipeline conveying gas or water, lightning arresters or telephone lines.</p>
 <p>The water heater shall not be installed at places where water drainage is unavailable or impossible.</p>	 <p>It is recommended that the water heater shall be installed inside.</p>
 <p>This water storage tank must be equipped with a safety valve. Its installation position shall not be changed. To guarantee safe operation, it shall not be blocked at any time.</p>	 <p>While bathing, children must be under guidance of an adult person.</p>

Safety instructions (to be followed at any time)

English

<p>⚠</p> <p>The outlet water temperature of a water heater is typically higher than the temperature indicated on the display. Hot water shall not be pointed at the human body immediately after opening the hot water valve to avoid injury caused by hot water.</p>	<p>⚠</p> <p>Means for disconnection from the main supply having a contact separation in all poles that provide full disconnection under overvoltage category III conditions must be incorporated in the fixed wiring in accordance with the wiring rules.</p>
<p>⚠</p> <p>Install the water heater in strict accordance with the installation instruction specified on page 11-23.</p>	<p>⚠</p> <p>If the power cord is damaged, it shall be replaced by qualified professionals to avoid hazards.</p>
<p>⚠</p> <p>Hands or other items shall not be put into the air grille to avoid injury or damage to the water heater.</p>	<p>⚠</p> <p>Maintenance shall be carried out according to the instructions specified on page 28.</p>

Safety instructions (to be followed at any time)

<p>ⓘ Rotate the safety valve handle once a month. The valve works well if there is water flowing out, otherwise check for blocking and replace the safety valve if necessary.</p>	<p>ⓘ Water heaters shall be equipped with a dedicated power line and residual current circuit breakers. The action current shall not exceed 30 mA;</p>
<p>ⓘ The water drain pipe shall be in connection with the atmosphere, it shall not be blocked; the water drain pipe connected to a safety valve shall be installed in a frostless environment with an continuous downwards inclination.</p>	
<p>ⓘ Refrigerant: R134a; When handling product, you should</p> <ul style="list-style-type: none">- No smoking- Prevent the accumulation of electrostatic charges- Work in a well ventilated place.- Avoid contact with the skin and eyes- Do not inhale the vapours- Evacuate the hazardous area- Stop the leakage <p>ⓘ The appliance contains fluorinated greenhouse gases. Chemical name of the gas: R134a Fluorinated greenhouse gases are contained in hermetically sealed equipment. An electrical switchgear has a tested leakage rate of less than 0.1 % per year as set out in the technical specification of the manufacturer. The quantity expressed in weight and in CO₂ of fluorinated greenhouse gases for which the appliance is designed, and the global warming potential of those gases. (R134a, GWP 1430)</p>	

Instructions on transportation and storage

1. During transportation or storage, the heat pump water heater shall be packed in the undamaged package to avoid damage to appearance and performance of the product;
2. During transportation or storage, the heat pump water heater shall be in the upright position;

English



The external unit shall be kept in the upright position at any time for the best performance !

Functionings & principles

A low-pressure liquid refrigerant is vaporized in the heat pump's evaporator and passed into the compressor. As the pressure of the refrigerant increases, so does its temperature. The heated refrigerant runs through a condenser coil within the storage tank, transferring heat to the water stored there. As the refrigerant delivers its heat to the water, it cools and condenses, and then passes through an expansion valve where the pressure is reduced and the cycle starts over.

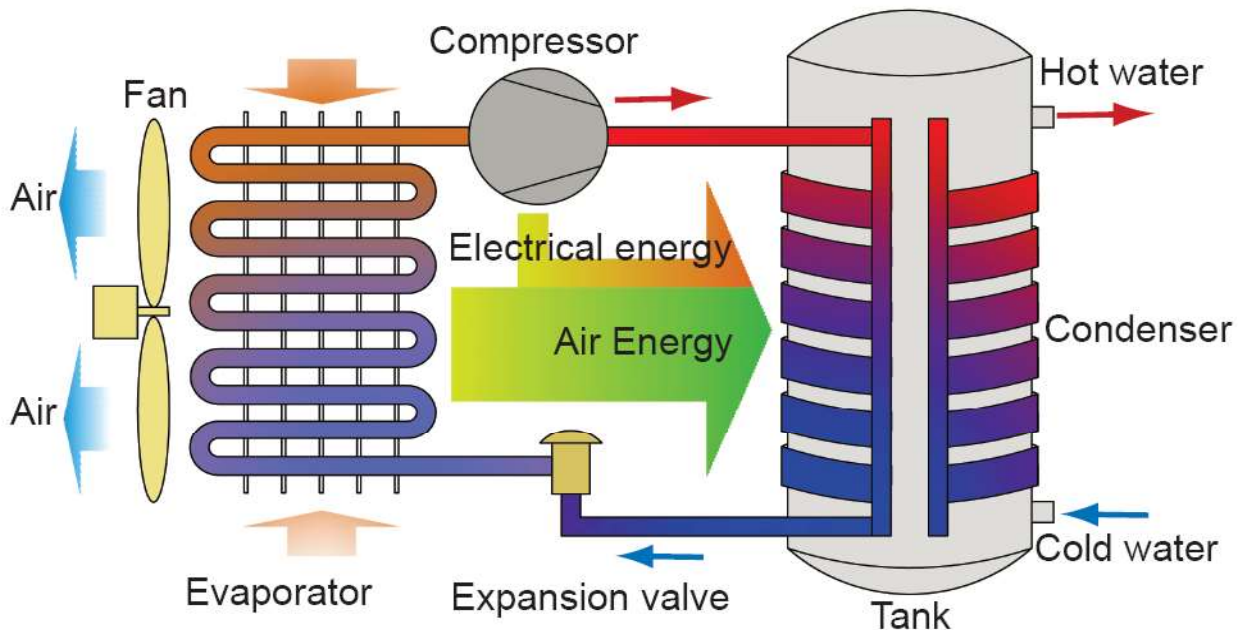

Technical parameters

Model (system)	HP200S1	HP300S1
Model (tank unit)	TS200HE-S1	TS300HE-S1
Model (external unit)	UE1.0-S1	UE1.5-S1
Tank volume	195L	293L
Rated voltage/ frequency	230V/50Hz	230V/50Hz
Tank rated pressure	0.85MPa	0.85MPa
Corrosion protection	Magnesium rod(x2)	Magnesium rod(x2)
Water proof grade	IPX4	IPX4
Assembled System		
Power input by electric backup	2150W	2150W
Rated power input by heat pump	665W	885W
Maximum power input by heat pump	1000W	1350W
Maximum power input	3150W	3500W
Default temperature setting	55°C	55°C
Temperature setting range- with heater	35°C-75°C	35°C-75°C
Maximum length of refrigerant pipe	20m	20m
Max working pressure of refrigerant	0.8/2.8MPa	0.8/2.8MPa
Refrigerant type / weight	R134a/1.3kg	R134a/1.5kg
Sound power level	64dB	64dB
Ambient temperature for use of product	-7~45°C	-7~45°C
Operating temperature of heat pump	-7~45°C	-7~45°C
Performance certified at 7 ° C air (CDC LCIE 103-15 / B)		
Type of extraction	Exterior	Exterior
Coefficient of performance (COP)	3.09	3.20
Standby power input/ Pes	28W	29W
Tapping cycle	L	XL
Heating up time	4h03	4h45
Reference temperature /Tref	53.86°C	53.91°C
Max volume of usable hot water at 40°C setting at 55°C	245.1L	382.6L
Dimension and connections		
Water inlet and outlet connection	R3/4"F	R3/4"F
Safety valve connection	R3/4"F	R3/4"F
Drain & Water intlet connection	R3/4"F	R3/4"F
Product dimension (tank unit)	544*512*1765 mm	632*600*1795 mm
Product dimension (external unit)	899*352*681 mm	899*352*681 mm
Packing dimension (tank unit)	676*636*1927 mm	737*696*1958 mm
Packing dimension (external unit)	960*425*735 mm	960*425*735 mm
Net/Gross weight (tank unit)	77/89kg	98/112kg
Net/Gross weight (external unit)	41/44kg	44/48kg
* The COP and noise level data was tested in Haier lab.		

Description of parts and components

Heat pump structure

English

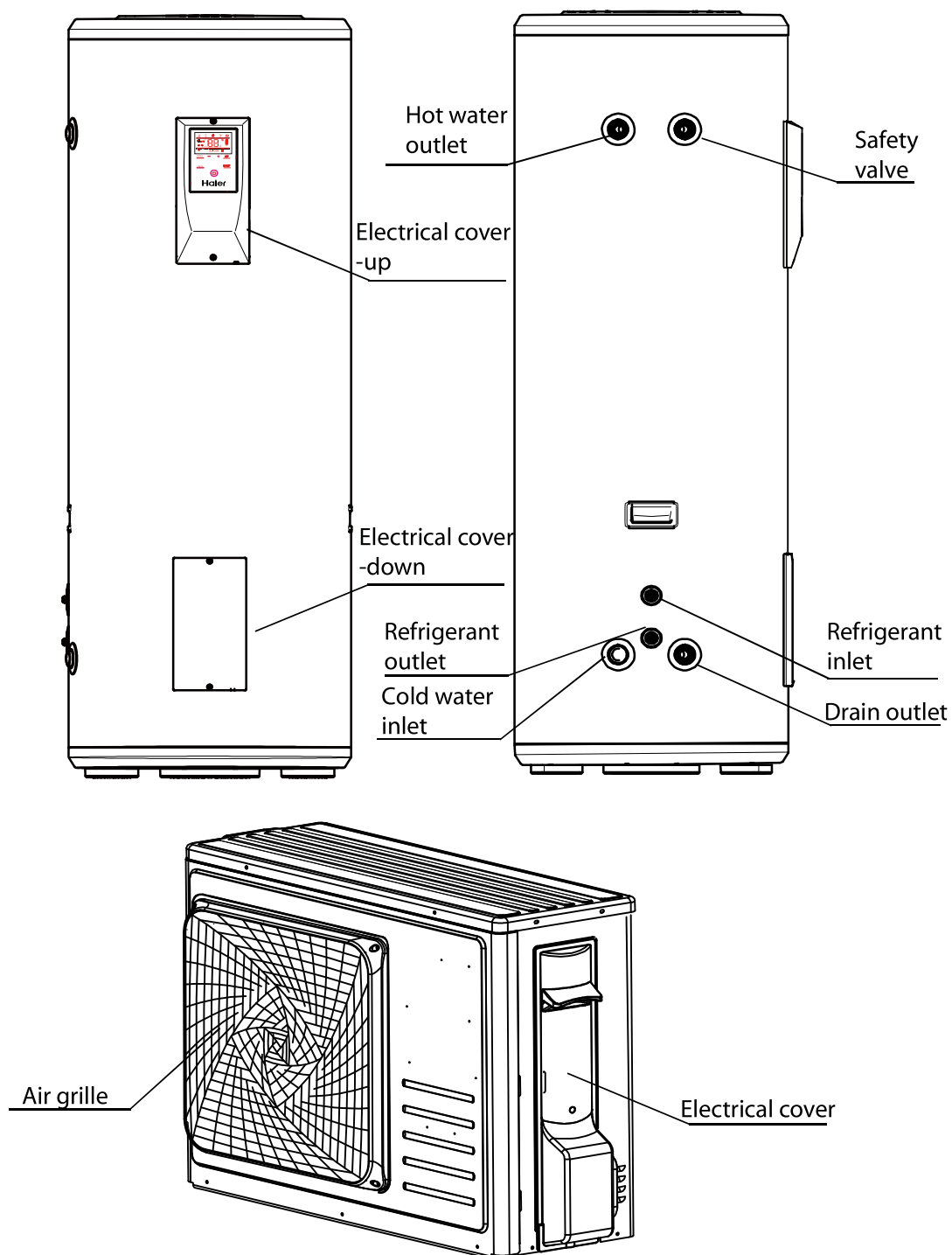

HP200S1/HP300S1

Description of parts and components

Exploded view (tank unit)

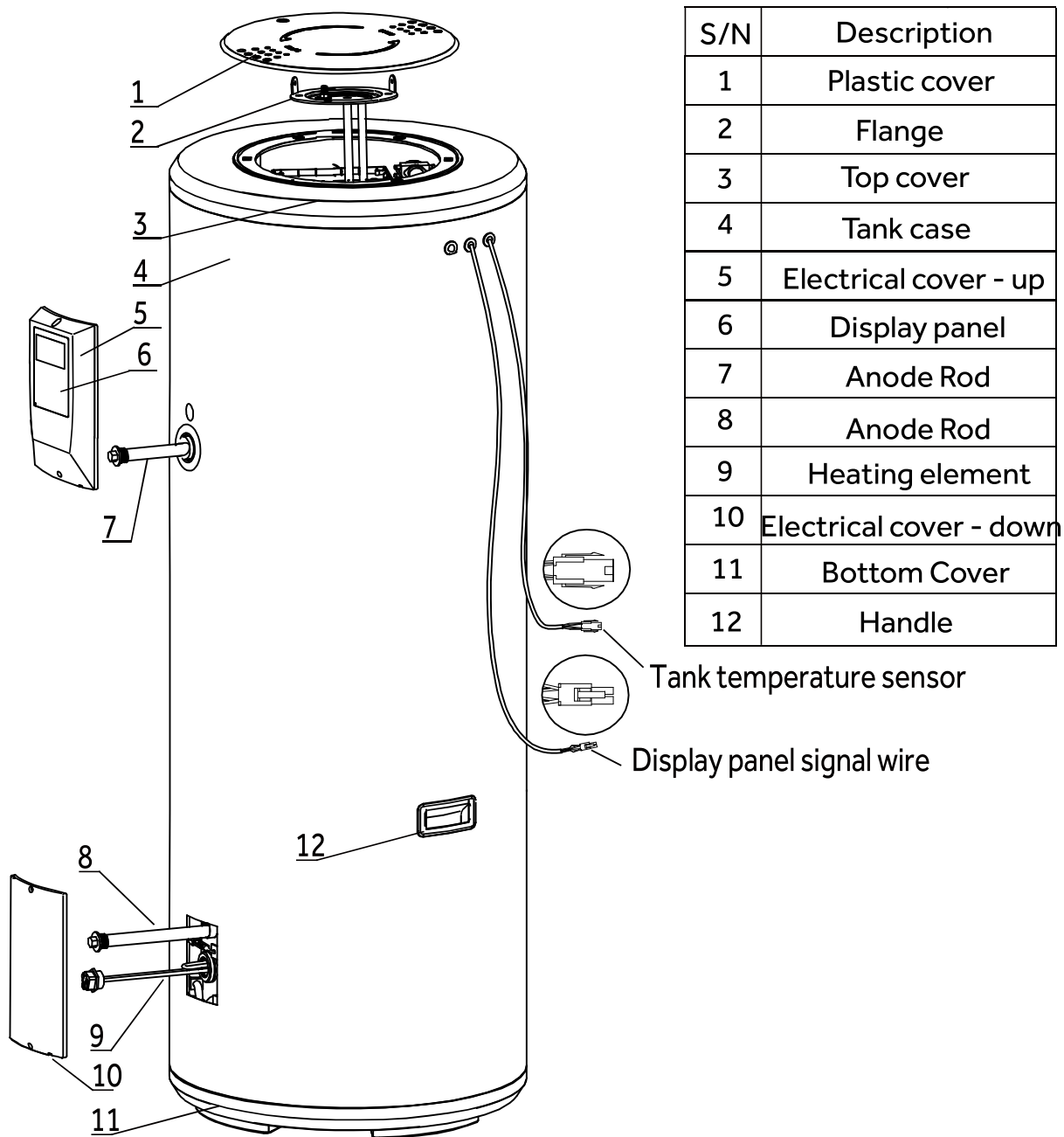

S/N	Description
1	Plastic cover
2	Flange
3	Top cover
4	Tank case
5	Electrical cover - up
6	Display panel
7	Anode Rod
8	Anode Rod
9	Heating element
10	Electrical cover - down
11	Bottom Cover
12	Handle

English

Accessories (tank unit)

Part name	Tank	Fiber washer	The strap of tank	Instruction manual	Expansion bolts	Signal wire	Dielectric connection
Quantity	1	4	1	1	2	2	2

Description of parts and components

Exploded view (external unit)

English

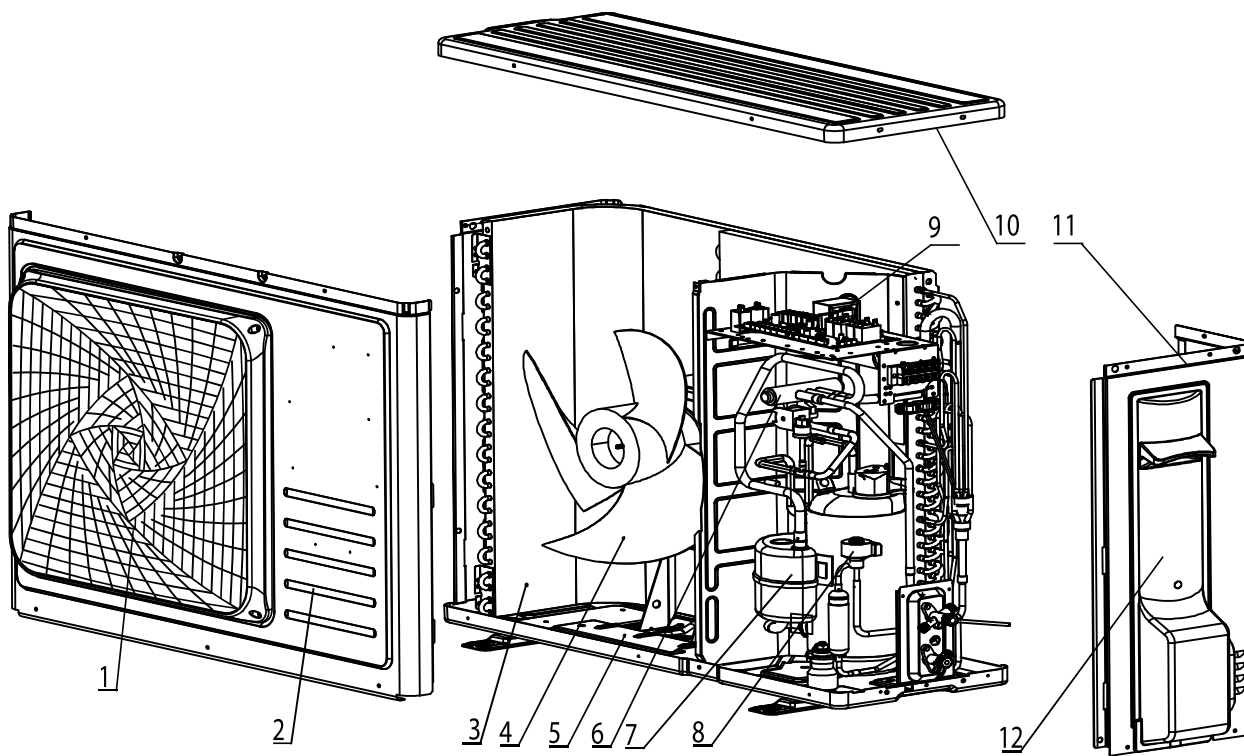

S/N	Description	S/N	Description
1	Air grille	7	Compressor
2	Front cover	8	Expansion valve
3	Evaporator	9	Controller panel
4	Fan	10	Top Cover
5	Bottom Cover	11	Right Cover
6	Four-way valve	12	Electrical cover

Accessories (external unit)

Part name	External unit	Drain pipe for condensate water	Elbow	Protective ring	Rubber pad	Expansion bolts
Quantity	1	1	1	2	4	4

Installation introduction

Installation precaution

- Do not install the water heater in the position where exposed to gas, vapours or dust.
- Install the tank unit and external unit on a flat, solid surface. The surface can support the machine weight and the condensate water can be drained freely.
- Noise due to operating and air flow do not bother neighbors.
- Make sure there is sufficient space left for installation and maintenance.
- There is no strong electromagnetic interference around that may affect control functions.
- There is no sulfur gas or mineral oil existing at the installation place, which may cause corrosion of the machine and the fittings.
- The water pipe for the water heater used at temperatures below 0°C shall not freeze.
- It shall not be set in rooms where a heating system is used so that heating supply to the room will not be affected.
- It shall not be set inside a totally-enclosed space.
- The air taken in must in no event be dusty.
- Install the internal unit in a dry, frost-free room.
- Temperature of the ambient air or of the air taken in by the heat pump for optimum running: from 10 to 35°C.
- Discharge of condensate : The condensate or water, which is formed in the outdoor unit during heating operation, must be eliminated, freely or through the drain. Fix the drain connection into the hole which is located on the bottom of the unit and connect the plastic tube with the connector. Ensure that the condensate water runs out in a suitable drain and make sure the discharge is made without hindrance.

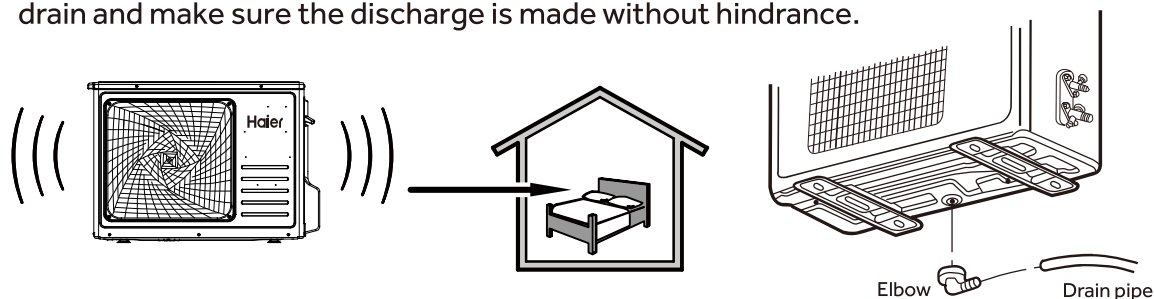

Keep an adequate distance between the working heat pump and the resting places.

Installation introduction

Installation dimensions

English

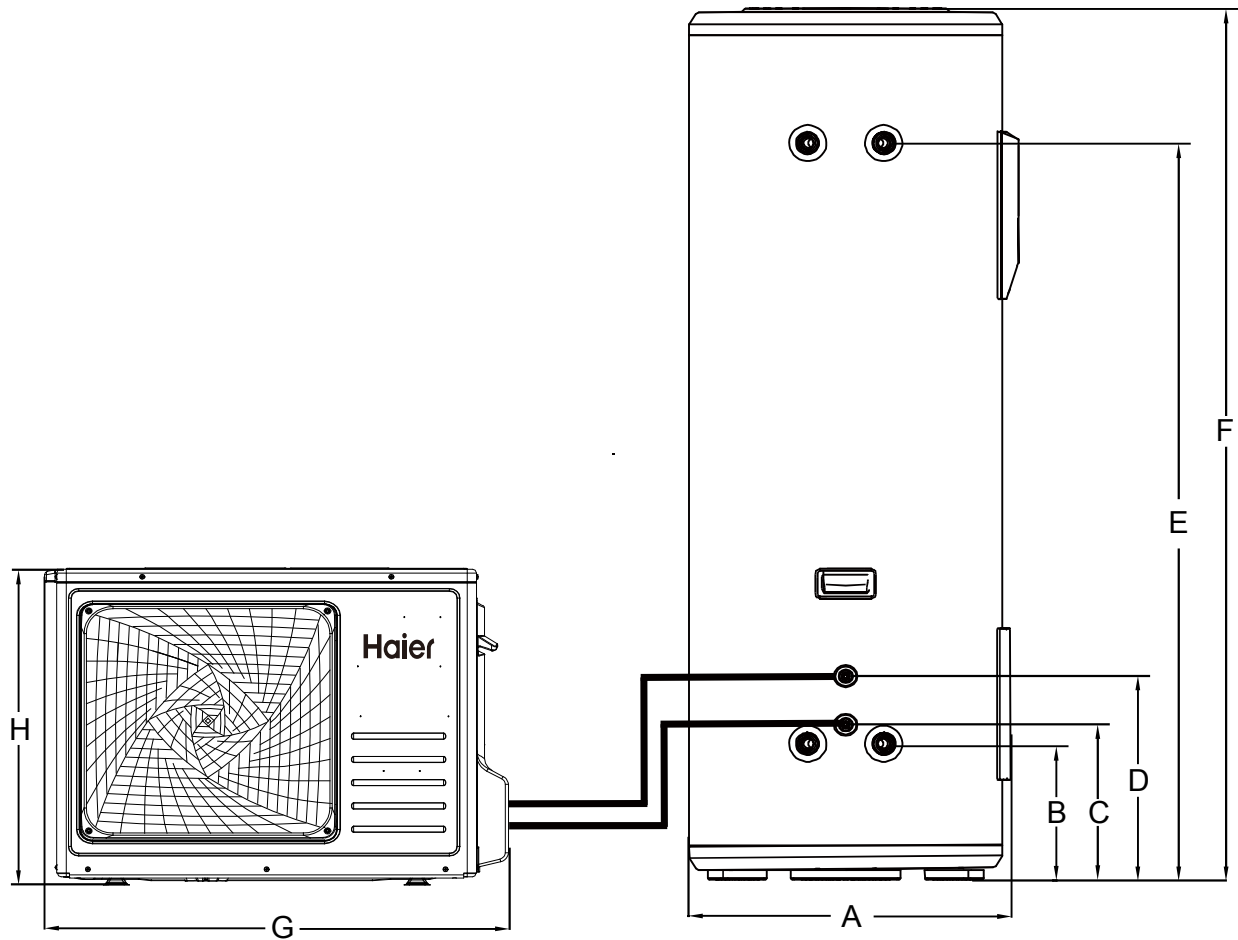

Unit:mm

Model	A	B	C	D	E	F	G	H
HP200S1	542	272	311	411	1530	1765	899	681
HP300S1	630	281	320	420	1519	1795	899	681

Installation introduction

Installation dimensions(external unit)

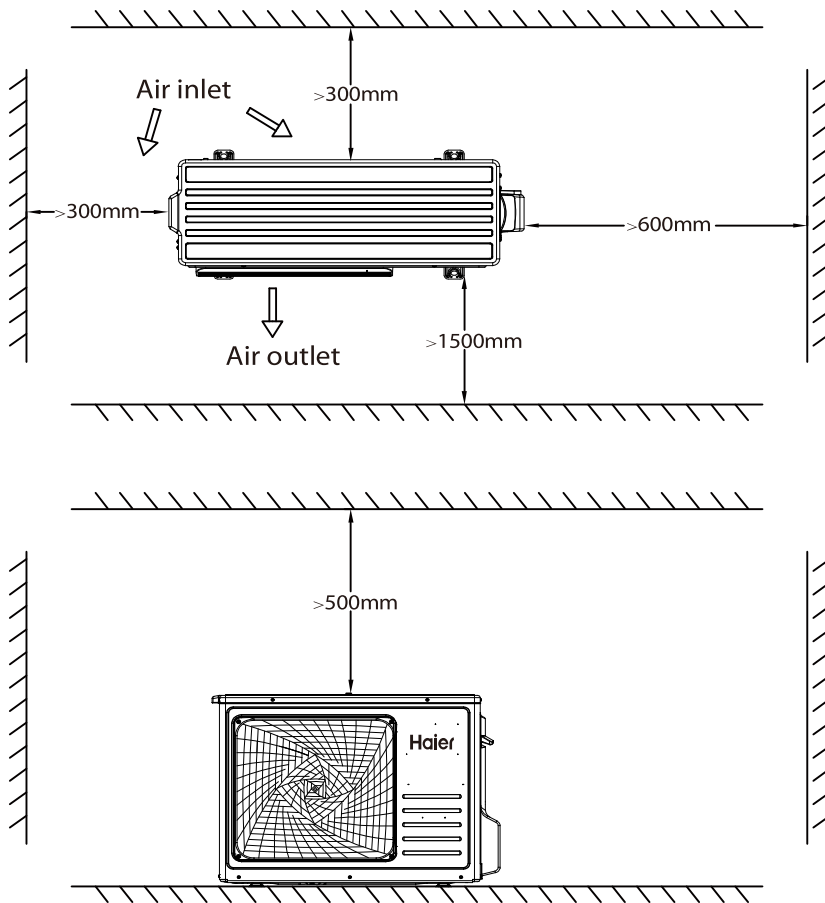

English

Installation dimensions(tank unit)

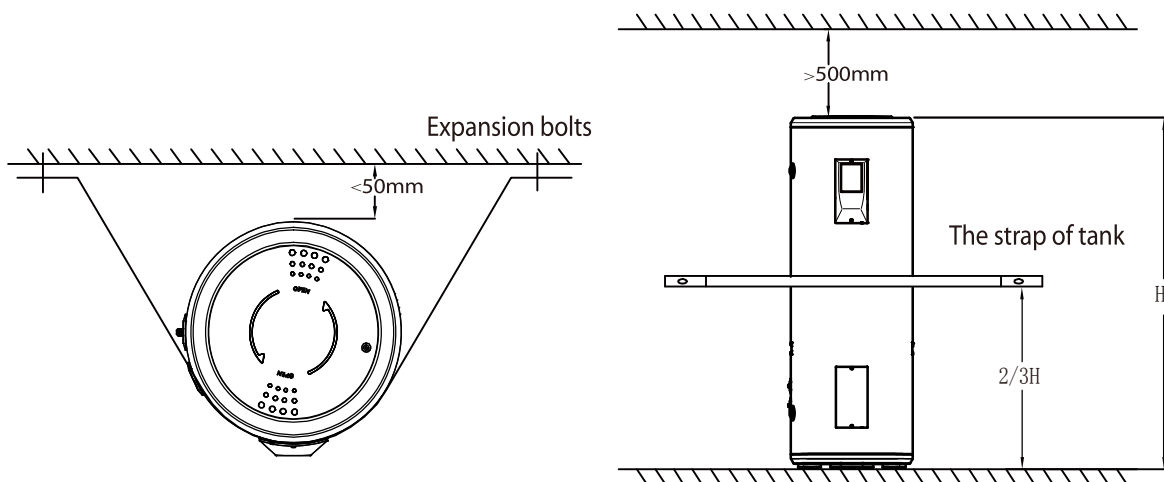

Installation introduction

Tools for the connection of refrigerant lines

- a) Group manometer suitable for use with R134a, with charge and vacuum tubes;
- b) Vacuum pump;
- c) Torque wrenches for nominal diameter of 1/4 "and 3/8" sizes on both sides to respond to the measures of the pipe unions;
- d) Flaring clamp \varnothing nominal 1/4 "and 3/8", equipped with a terminal receiving opening so that the projection of the copper tube can be adjusted from 0 to 0.5 mm in the working folder ;
- e) Pipe cutter;
- f) Pipe reamer;
- g) Leak Detector for R134a, a leak detector is used exclusively for HFC refrigerants. It must have a high detection sensitivity.

English

Preparing of the refrigerating pipes

WARNING! Before carrying out any installation check the following:

- a) Use only copper tubes for air conditioners type (copper tubing for the refrigeration and the conditioning) or copper pipes with proper insulation (at least 6 mm thick), suitable for use with R134a;
- b) Never use piping with a thickness less than 0.8 mm;
- c) Provide a path of the pipes as short and simple as possible (maximum length 20 m with 10 m of fall). Do not provide a path that may obstruct the access to the cap and the removal of flange.
- d) Protect the pipes and cables to avoid damage;

WARNING! The refrigerant lines, and fittings for connection must be insulated to avoid dangerous burns, loss of performance and product malfunction. Ensure the insulating sheath of the tubes through fastening clamps to prevent it from moving.

Installation introduction

Connecting the tank unit

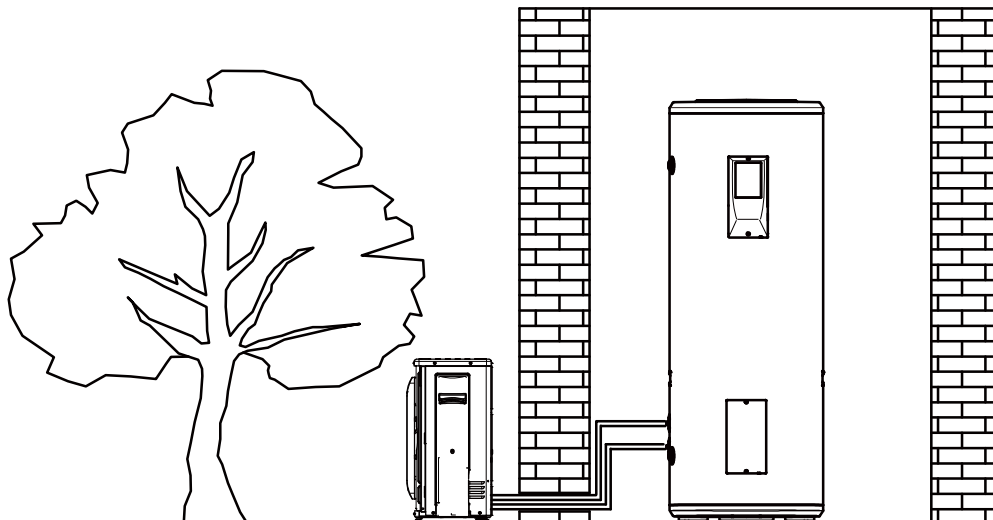

English

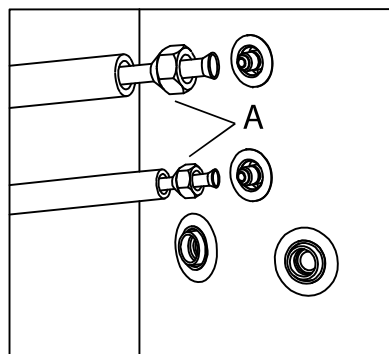
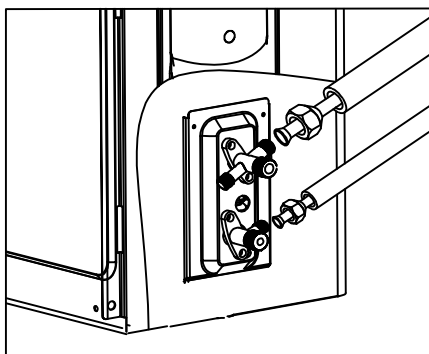

- a) Shape the pipes according to the path;
- b) Remove the threaded brass flare nuts(A) on the tank unit and store them (check that no impurities are left);
- c) Cut the pipe to the fixed length, with a pipe cutter, avoiding any deformation;
- d) Remove burrs with pipe reamer avoiding to get impurities inside (keep down the tube);
- e) Insert the threaded brass flare nuts(A) on the pipes in the correct direction;
- f) Insert the tube into the flaring tool and make the flange at the end of the connecting pipe, as indicated in the table.

Pipe(not supplied)	Specification	Thickness	Tightening torque [Nm]
Inlet refrigerant pipe	φ6.35 mm (1/4")	0.8mm	15~20
Outlet refrigerant pipe	φ9.5 mm (3/8")	0.8mm	29~34

After confirming that there are no wrinkles or tears on the flare, connect the pipes using two spanners, being careful not to damage the pipes. If the force is insufficient, then there will be leaks. Although the force is excessive, there may be losses because it is easy to damage the flange. The safest method is to tighten the connection by using a spanner and a torque wrench.

Installation introduction

Connecting the external unit



When making the connections, you should respect the standards and local directives.

Remove the flare nuts from 2 and 3 way valves, Insert the flare nuts on the pipes, screw the flare nuts to connect the external unit with the same method described for the tank unit.

Making the vacuum

English

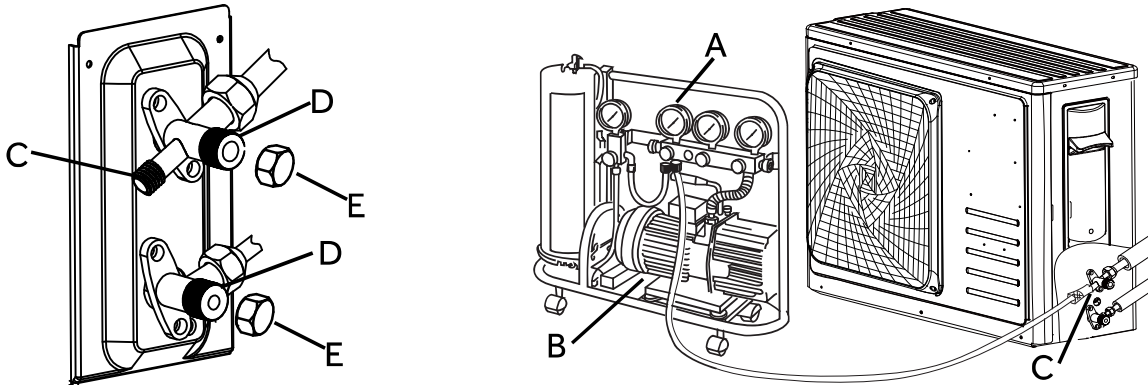

Bleeding from the circuit should take place with a vacuum pump and pressure gauge assembly suitable for R134a.

Make sure the vacuum pump is full of oil up to the level indicated by the oil gauge.

- loose the caps of the taps of the 2 and 3 way valves, and of the service valve; verify that the two valves on the outdoor unit are closed (D);
- connect the vacuum pump (B) to the service valve (C) by the attack of low pressure gauge (A);
- After opened the valves of the vacuum pump (B), start it and let it run. Create a vacuum for about 20 / 25 minutes;
- verify that the low pressure gauge (A) indicates a pressure of 1 bar-(or -76 cm Hg);
- close the valves of the pump and shut off (B). Verify that the gauge needle does not move for about 5 minutes.

If the needle moves, there are air leaks in the system, then you must check all the tightening and execution of flare at this point repeat the procedure from step c;

f) Disconnect the vacuum pump, (if you want to add refrigerant gas see the next paragraph);

g) completely open the taps on 2 and 3 way valves (D);

h) Screw in the cap on the service outlet and valves (E);

i) after having tightened the plugs, make sure there are no gas leaks with the appropriate detector.



Always protect hoses and cables to prevent their being damaged, as once damaged can cause gas leaks (personal injury from frostbite).

Installation introduction

Charge of the refrigerant gas

The product can be installed with refrigerant connection between internal and external unit up to 20 m. The declared performances are referred to refrigerant connection pipes of 5 m; different types of installation may lead to different values of performance.

In case you are adding R134a gas in the circuit, will be needed:

- R134a refrigerant tank. In this case it is necessary a charge attack 1/2 UNF 20 threads per inch and corresponding seal;
- Electronic scale for refrigerant charging with sensitivity 10g.
- Connection pipes over 10 m need to increase the refrigerant(30g / m).

During installation:

- Carry out the procedure of passage "a" to the passage "f";
- Connect the manometer on the low pressure service valve, and connect the refrigerant cylinder to the center tap of the the manometer. Open the container of the refrigerant then open the main valve cap pressure gauge and adjust the needle valve until you hear the coolant leak, and release the pin and close the valve of the the pipe;
- Keep under control the weight of the refrigerant tank through the electronic scale;
- Open the ball valve and to flow the refrigerant gradually;
- After reaching the mass of gas to be loaded close the tap;
- Remove the manometer and charging hose from the valve;
- Fully open taps 2 and 3 way valves (D), turn the product in heat pump mode with the detector and check for leaks of refrigerant;
- Remove the container from the manifold and replace all the plugs (E).

Already installed:

- Connect the manometer on the low pressure service valve, and connect the refrigerant cylinder to the center tap of the the manometer. Open the container of the refrigerant then open the main valve cap pressure gauge and adjust the needle valve until you hear the coolant leak, and release the pin and close the valve of the the pipe;
- Keep under control the weight of the refrigerant tank through the electronic scale;
- Open the ball valve and to flow the refrigerant gradually;
- After reaching the mass of gas to be loaded close the tap;
- Remove the manometer and charging hose from the valve;
- with the detector and check for leaks of refrigerant;
- Remove the container from the manifold and replace all the plugs (E).
- Once finished the time for the "Charge", verify proper product functioning.

Installation introduction

Installation caution



When making the connections, you should respect the standards and local directives.

- Select copper pipes for pipeline connection.
- The inlet water pressure is between 0.1~0.6MPa. If lower than 0.1 MPa, a booster pump shall be added at the water inlet; if higher than 0.6 MPa, a pressure relief valve shall be added at the water inlet.
- The inlet water temperature is suggested between 10-30°C.
- Outdoor water pipeline and valves should be proper insulated.
- In accordance with safety rules, a safety valve(8.5bar,99°C,R3/4M) must be installed on the tank.For France, we recommend hydraulic safety units fitted with a membrane with the NF marking.
Integrate the safety valve in the cold water circuit.Install the safety valve close to the tank in a place which is easy to access.
No isolating devices should be located between the safety valve or unit and the tank.
- Never block the outlet of the safety valve or its drain line for any reason.
- The diameter of the safety unit and its connection must be atleast equal to the diameter of the domestic cold water inlet.
- If the mains pressure exceeds 80% of safety valve, a pressure reducer must be installed upstream of the appliance.



Do not connect the cold water inlet and hot water outlet directly to the copper pipes in order to avoid iron/copper galvanic couples (risk of corrosion). The cold water inlet and hot water outlet must be fitted with a dielectric connection .
R 3/4" dielectric connection and pipe fittings must be used ,DO NOT use G 3/4" thread.

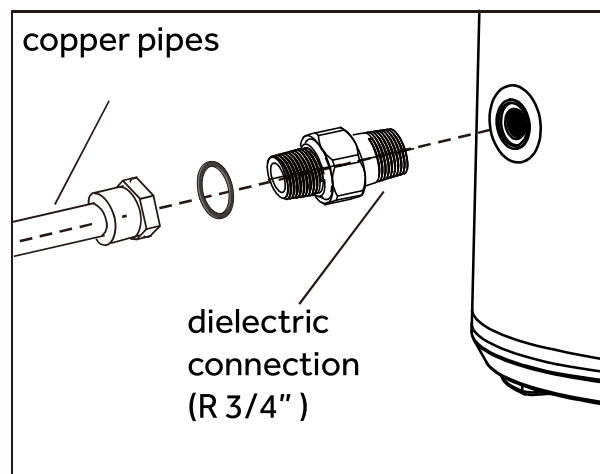

Installation introduction

Pipeline installation diagram

Installation A

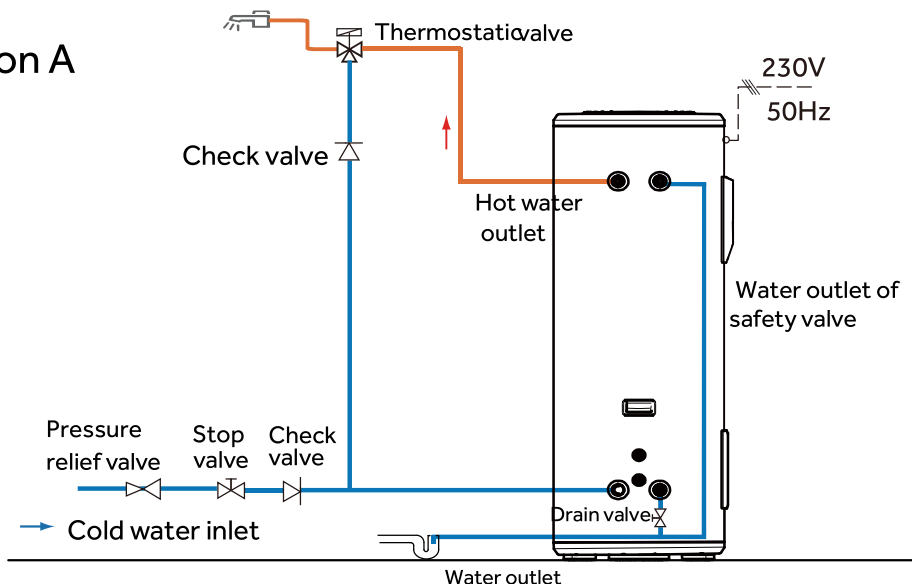

Installation B(for France only)

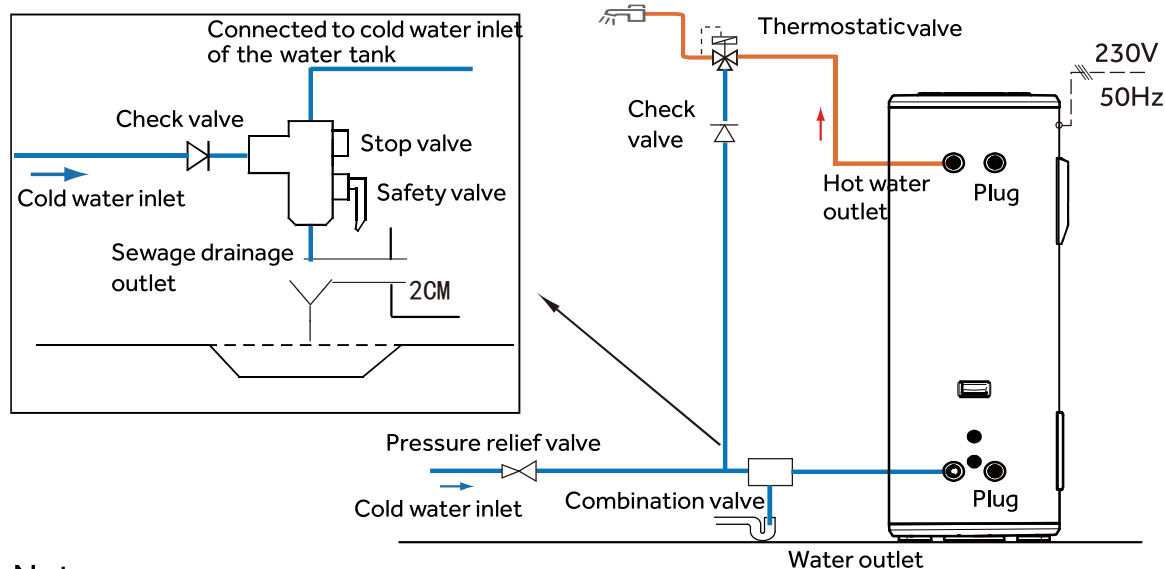

Note:

- Pressure relief valve, thermostatic valve, stop valve, check valve, T&P valve and French combination valve are not included in the accessories, please select proper fittings in local market;
- Valves with NF/CE certification are recommended ;
- In accordance with safety rules, a safety valve(8.5bar,99°C,R3/4M) must be installed on the tank. For France, we recommend hydraulic safety units fitted with a membrane with the NF marking.
- The inlet water pressure is between 0.1~0.6MPa. If lower than 0.1 MPa, a booster pump shall be added at the water inlet; if higher than 0.6 MPa, a pressure relief valve shall be added at the water inlet.
- The inlet water temperature is suggested between 10-30°C.

Installation introduction

Electrical connections precautions



WARNING

- Only qualified professionals may carry out electrical connections, always with the power off.
- The earthing shall comply with local standards.

English

- The heat pump water heater requires a single phase 16A(HP200S1)/20A(HP300S1) supply requiring a licensed electrician for connecting.
- Water heaters shall be equipped with a dedicated power line and residual current circuit breakers. The action current shall not exceed 30 mA;
- The earth wire and the neutral wire of the power supply shall be separated entirely. Connecting the neutral wire to the earth wire is not allowed.
- Parameter of the alimentation cable: $3 \times 2.5 \text{ mm}^2$ or more.
- If a power cable is damaged, it shall be replaced by qualified professionals to avoid risks.
- In the case of places and walls where water may be splashed to, installation height of a power socket shall not be less than 1.8 m, and it shall be ensured that water would not be splashed on these places. The socket shall be installed out of children's reach.
- The live wire, neutral wire and earth wire inside a power socket used in your home shall be wired correctly without any wrong positioning or false connection, and internal short circuit shall be avoided. Wrong wiring may cause fire accidents.

Attention!

Through poor conditions of the electrical MAINS, shortly voltage drops can appear when starting the EQUIPMENT. This can influence other equipment (eg. blinking of a lamp). If the MAINS-IMPEDANCE $Z_{\text{max}} < 0.304 \text{ OHM}$ (HP200S1) $Z_{\text{max}} < 0.289 \text{ OHM}$ (HP300S1), such disturbances are not expected. (In case of need, you may contact your local supply authority for further information).

Installation introduction

Electrical connections

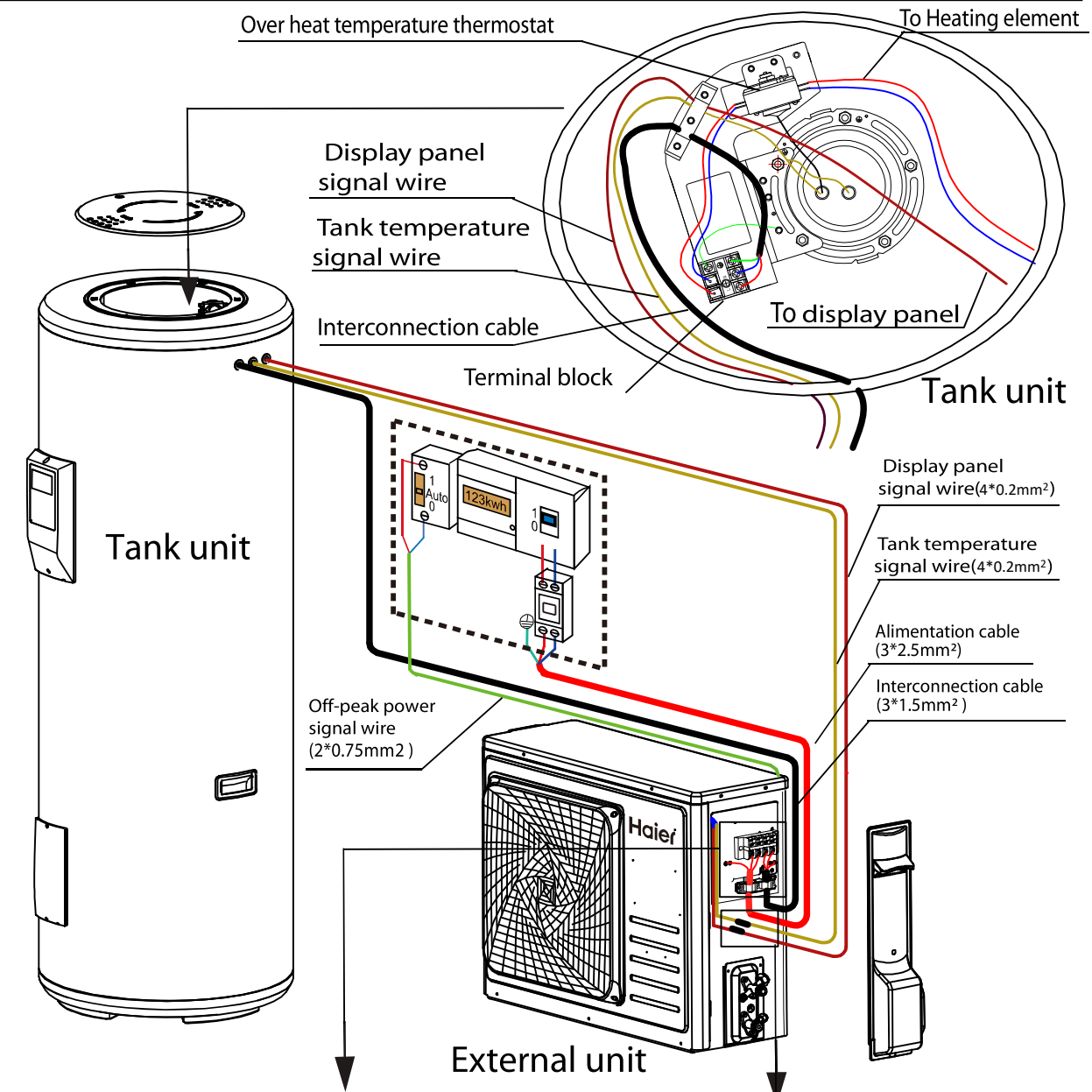

English

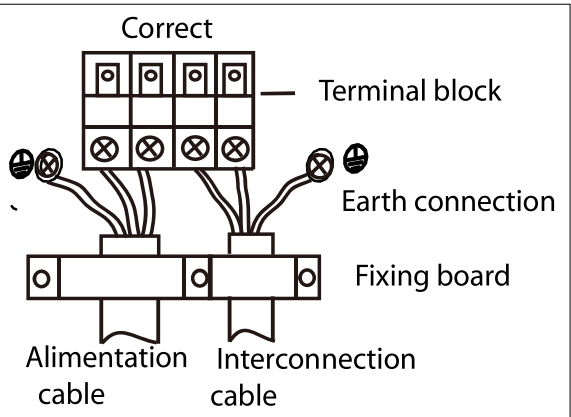

Cable connection

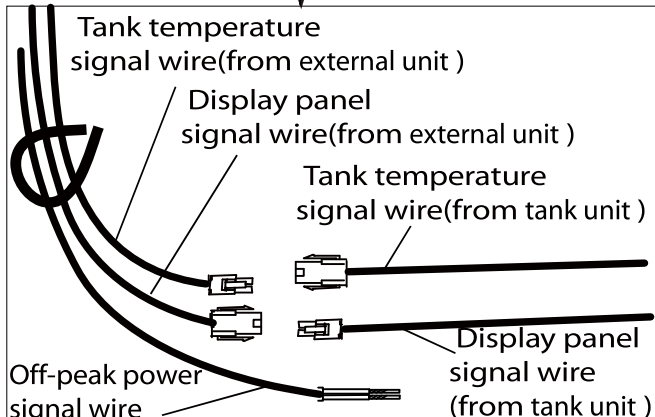

Signal wire connection

Installation introduction

Electrical connections

Connecting the cables and signal wire:

- a) Remove the electric cover of tank unit, and connect the Interconnection cable to the terminal block, you must use the fixing board to press the cable, then install the electric cover.
- b) Remove the electric cover of external unit. Connect the alimentation cable and interconnection cable, according to the wiring diagrams.
- c) Connect the display panel signal wire, the tank temperature signal wire and Off-peak power signal wire.
- d) After connection, you must use the fixing board to press the cable. Fixing board should be pressed against the outer sheath of the cable.
- e) Install the electric cover of external unit.

Description	Availability	Cable	Type
Alimentation cable	not supplied	3*2.5mm ²	H05RN-F
Interconnection cable	not supplied	3*1.5mm ²	H05RN-F
Off-peak power signal wire	supplied	2*0.75mm ²	H03VVH2-F
Tank temperature signal wire	supplied	4*0.2mm ²	shielded – UL2464
Display panel signal wire	supplied	4*0.2mm ²	shielded – UL2464

Commissioning

Installers shall use checking list for trial operation of water heaters as per the user manual and make ✓ in □.

- Electrical wires are fixed securely?
- Water drain pipes are connected correctly?
- Ground wires are connected securely?
- Supply voltage conforms to relevant electric codes?
- The control panel works well?
- All noises are normal?
- The water tank has been connected with dedicated pressure relief valve (TP valve) and check valve?
- Materials for hot/cold water pipes conform to requirements of use of hot/cold water?
- After the water system is completed, the water tank is filled with water? Is there water drained out of the water outlet of the hot water pipeline?
- After the water pipe of the water system is filled, check the whole water pipeline. There is no leakage?
- After the water system is filled with water, is there water flowing out after pressure is relieved via the automatic safe pressure relief valve?
- After the water system is filled with water and after leakage check, all outdoor water pipelines are applied with heat insulation treatment?
- The drain valve, drain pipe and pressure relief valve drain pipe of the water tank have been connected to the sewage system and the drainage can be carried out well?

Installation introduction

Wiring diagram

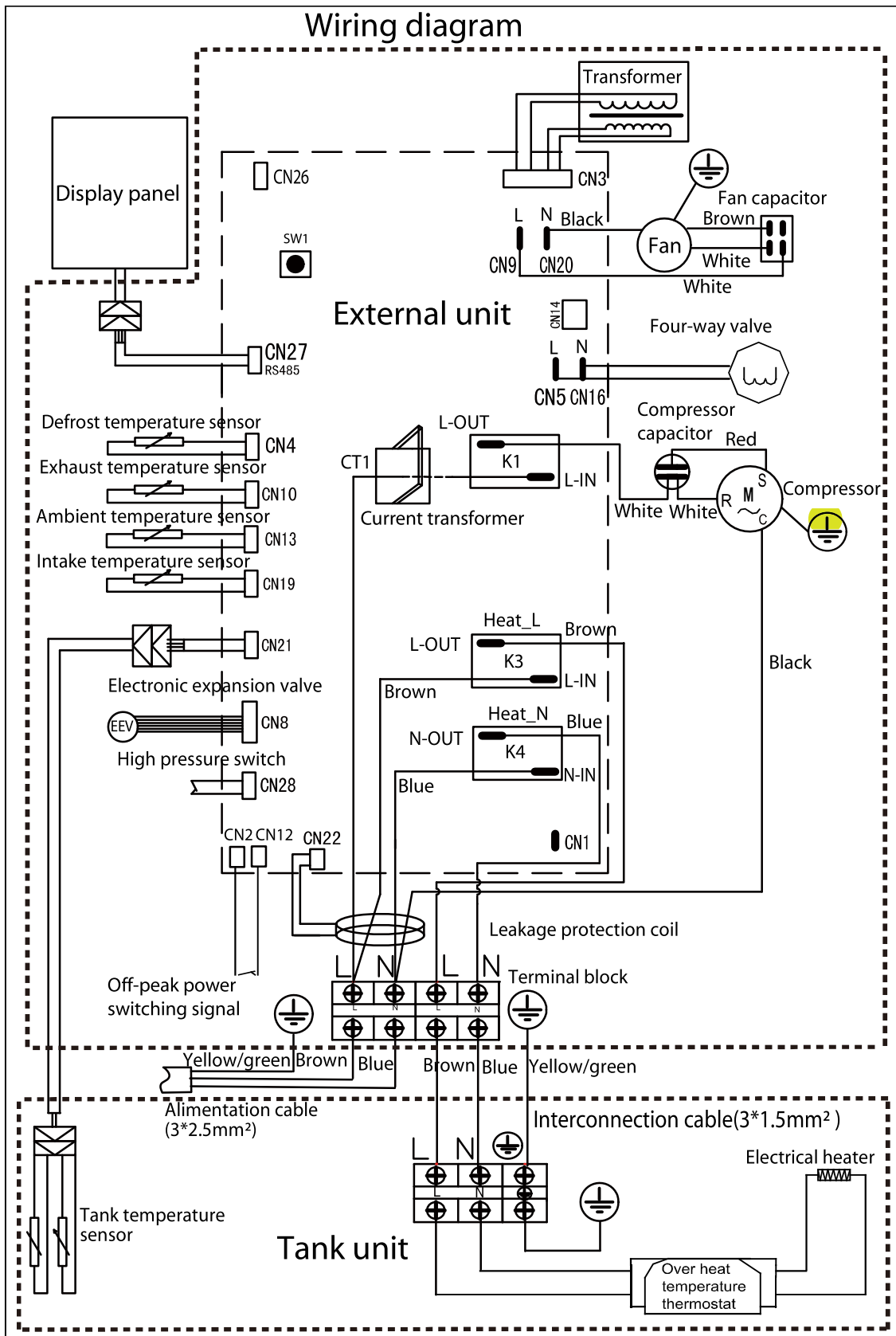

English

Operation and functions

Display



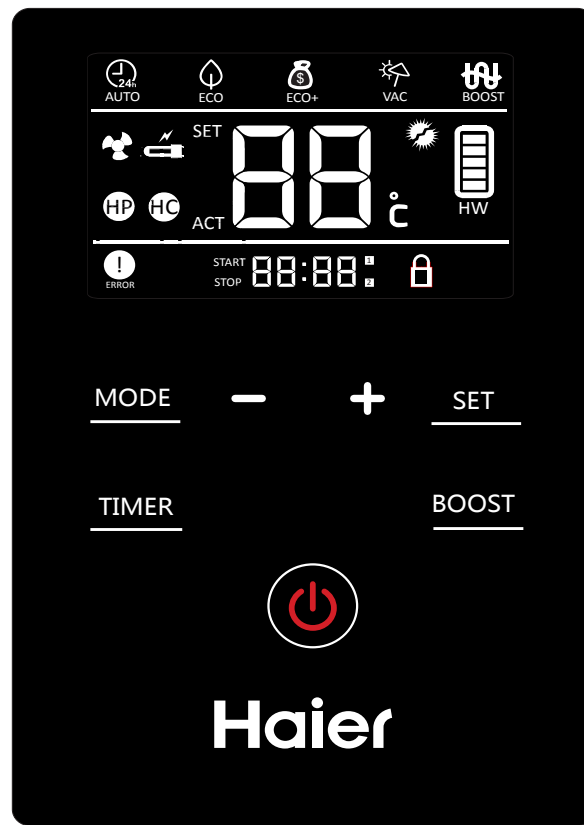

English









Description of the pictograms

Symbol	Description
	Power ON/OFF switch When turned off, the display shows the time and the actual water temperature. When turned on, the display shows the working mode. The default temperature setting is 55°C in the factory. It can be adjusted simply by pressing + & - directly on the default display.
MODE	Working mode selection: Press the key, the AUTO mode, ECO mode, ECO+ mode, VAC mode is displayed in turn. Press SET or wait 6 seconds the mode is selected.
SET	Confirm button
TIMER	Timer adjust: press this key, then Press the + and - to adjust the time.
BOOST	Turn on or off fast heating function: Heat pump and Auxiliary electrical heater are activated at same time (only in AUTO mode).

Description of the pictograms

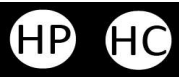
Symbol	Description
	<p><u>Auto mode</u></p> <ul style="list-style-type: none"> - Optimised management of the heat pump and the electrics for guaranteed comfort; - Prior using heat pump; - If compressor works more than the default 8 hours , start the auxiliary power; - The compressor maximum continuous working time(AA) can be adjust in the installer settings.
	<p><u>ECO (off-peak) mode</u></p> <ul style="list-style-type: none"> - In this mode ,priority using heat pump,start the Auxiliary electrical heater only in off-peak time; - In two ways using heat pump,should set in the installer settings in advance ; 01- timer refer to LP parameter; 02-switch signals by power companies. - In 01 mode, Press SET, press + and - to set Start time of first Low price L1. Than,set Colsed time of L1. And than, press SET, to defined for L2. - In 02 mode, HC light up in Time of Off-peak hours, HP light up in Peak hours.
	<p><u>ECO+ (off-peak) mode</u></p> <ul style="list-style-type: none"> - In this mode ,priority using heat pump, heat pump and Auxiliary electrical heater are activated only in off-peak time; - In two ways using heat pump,should set in the installer settings; 01- timer refer to LP parameter; 02-switch signals by power companies. - In ECO+ mode, The Start time and Colsed time settings as the ECO (off-peak) mode .
	<p><u>Holiday mode</u></p> <ul style="list-style-type: none"> - According to the vacation dates in advance to prepare hot water; - For example, you leave home for vacation on January 1st and return home on January 5th. The date shall be set as (5-1) =4 days, and corresponding temperature shall also be set. The heat pump will start heating on 00:00 o'clock of January 5th automatically.





Description of the pictograms

Symbol	Description
	Boost mode. Heat pump and Auxiliary electrical heater are activated at the same time(only in AUTO mode).
	Heat pump working icon .
	Auxiliary electrical heater working icon .
	Time of peak/off-peak hours. In Time of peak/off-peak hours mode, the symbol corresponding to the mode is displayed.
	Alarm display icon.
	<u>Anti-legionella</u> - Anti-legionella function will be activated every 7 days to heat the tank to 65°C automatically .
	Hot water volume display.

Note: Under certain conditions, ECO mode and ECO+ mode may result in shortages of hot water (mainly due to air temperatures outside the operating range).

Operating functions

Installer settings

- To open the installer settings, press  switch off the system, then press  and **SET** at the same time for 10 seconds.
- When menu is open, press  or  to change the value of the settings.
- Press **SET** to confirm the settings.
- Press  to close the menu.

Parameters	Description	Factory setting	Adjustment range
LL NO, NC	<u>Off-peak signal type</u> When you use off-peak time clock control, first determine the type of signals, Only allow professional installers to operate. - NO corresponds to Normally Open Signal. - NC corresponds to Normally Close Signal.	NO	NO , NC
LP 01, 02	<u>Off-peak logic type</u> - In two ways using heat pump, should set in the installer settings -01 manually set off-peak time; -02 switch signals by power companies.	01	01 , 02
AL ON, OF	<u>Avoid Legionella</u> - This parameter is used to activate the legionella protection mode. - Once every 7 days, all domestic hot water is heated to 65°C.	ON	ON , OF
AA 5-10	<u>Compressor maximum continuous working time</u> - If the maximum continuous working time of the compressor more than Set Time, start auxiliary power.	8h	5-10h
EH ON, OF	<u>Auxiliary Heating in off-peak time</u> - ON corresponds to turned on uxiliary Heating. - OF corresponds to turned off uxiliary Heating.	ON	ON , OF

English

Checking and maintenance



- Installation and maintenance of the appliance must be done by a qualified professional .
- Before working on the appliance, Shut down the machine and cut off the power supply .
- Do not touch with wet hands.
- Maintenance operations are important to guarantee optimum performance and extend the life of the equipment.

Checking of the Safety valve

- Operate the safety valve at least once a month to check if it is running correctly. Otherwise check for blocking and replace the safety valve if necessary.

Checking of the hydraulic circuit

- Check the watertightness of the water connections.

Cleaning of the fan

- Check the cleanliness of the fan one time per year.

Checking of the evaporator



- Because the evaporator fins is very sharp. Risk of injury on your finger.
- Do not damage the fins. Avoid affecting the performance.

- Clean the evaporator at regular intervals using a soft-haired brush.
- If they are bent. Carefully realign the evaporator using a suitable comb.

Checking of the condensates discharge pipe

- Check the pipe cleanliness .
- An obstruction by dust may cause poor condensates flow or even a risk accumulation of water in the heat pump plastic base.

Checking of the Magnesium rod

- The magnesium anode should be replaced in time, avoid tank corrosion.
- Checking magnesium anode once every 2 years .In poor water areas need to shorten the time.

Drain the water tank to empty

- Cut off power supply and shut down water inlet valve, then drain the water tank to empty via the sewage outlet. Please stay away from the sewage outlet if there is hot water inside the water tank to avoid injury.

Faults and protection

Fault type	Action	Digital indication	Release
Compressor protection	Operating temperature protection	F2	After fault is solved, switch on power supply for release
	Air exhaust temperature protection	F3	
	Evaporation high temperature protection	F5	
Compressor over-current protection	Over-current protection	F6	
Electricity leakage alarming	The system will automatically cut off power supply if any line fault occurs	E1	After fault is solved, switch on power supply for release
Over temperature alarming	The actual water temperature 85°C	E2	
Fault of the inner temperature sensor	If short circuit or circuit break occurs to the sensor	E3	
Fault of the ambient temperature sensor	If short circuit or circuit break occurs to the sensor	E4	
Fault of the evaporation temperature sensor	If short circuit or circuit break occurs to the sensor	E5	After fault is solved, automatic recovery
Fault of the air exhaust temperature sensor	If short circuit or circuit break occurs to the sensor	E6	After fault is solved, switch on power supply for release
Fault of the air intake temperature sensor	If short circuit or circuit break occurs to the sensor	ED	
Communication fault	Communication of main control panel and display panel is abnormal	E7	After fault is solved, automatic recovery
Pressure switch protection	Action of the pressure switch at the exhaust outlet	E8	
Ambient temperature protection	Ambient or outdoor temperature <-7°C or>45°C	E9	
Fault of the Off-peak power switching signal	If not received the Off-peak signal when selecting switch signals by power companies	EF	



The  symbol on the product or on its packaging indicates that this product is not to be treated as regular household waste. Instead, it must be taken to a recycling collection point for electrical and electronic equipment. By properly disposing of this product, you are contributing to the preservation of the environment and the wellbeing of your fellow citizens. Improper disposal is hazardous to health and environment. You can obtain further information on how to recycle this product from your municipality, your waste management service or the shop where you purchased it.

Product Fiche

English

Model		HP200S1	HP300S1
Power supply	Ph/V/Hz	AC230V, 50Hz	AC230V, 50Hz
The water heating energy efficiency (η_{wh})	%	129.0	130.7
Water heating energy efficiency class	-	Class A+	Class A+
Annual energy consumption (AEC)	kWh/annum	804	1304
The daily electricity consumption (Q_{elec})	kWh	3.814	6.099
The sound power level (outdoors)	dB	64	64
Mixed water at 40 °C	L	245.1	382.6
Load profiles of water heaters, Type	-	L	XL
Refrigerant	g	R134a/1300g	R134a/1500g
Manufacturer	Qingdao Economic & Technology Development Zone Haier Water-Heater Co.,Ltd.		
Address	Haier Industry Park, Economic & Technology Development Zone, 266101 Qingdao, PEOPLE'S REPUBLIC OF CHINA		
Denomination	Heat pump water heater		
Intended use	Hot water		
Assembly	double package		

Load profiles of water heaters.

h	L				XL			
	Q_{tap} kWh	f l/min	T_m °C	T_p °C	Q_{tap} kWh	f l/min	T_m °C	T_p °C
7:00	0.105	3	25		0.105	3	25	
7:05	1.4	6	40					
7:15					1.82	6	40	
7:26					0.105	3	25	
7:30	0.105	3	25					
7:45	0.105	3	25		4.42	10	10	40
8:01					0.105	3	25	
8:05	3.605	10	10	40				
8:15					0.105	3	25	
8:25	0.105	3	25					
8:30	0.105	3	25		0.105	3	25	
8:45	0.105	3	25		0.105	3	25	
9:00	0.105	3	25		0.105	3	25	
9:30	0.105	3	25		0.105	3	25	
10:00					0.105	3	25	
10:30	0.105	3	10	40	0.105	3	10	40
11:00					0.105	3	25	
11:30	0.105	3	25		0.105	3	25	
11:45	0.105	3	25		0.105	3	25	
12:45	0.315	4	10	55	0.735	4	10	55
14:30	0.105	3	25		0.105	3	25	
15:00					0.105	3	25	
15:30	0.105	3	25		0.105	3	25	
16:00					0.105	3	25	
16:30	0.105	3	25		0.105	3	25	
17:00					0.105	3	25	
18:00	0.105	3	25		0.105	3	25	
18:15	0.105	3	40		0.105	3	40	
18:30	0.105	3	40		0.105	3	40	
19:00	0.105	3	25		0.105	3	25	
20:30	0.735	4	10	55	0.735	4	10	55
20:46					4.42	10	10	40
21:00	3.605	10	10	40				
21:15					0.105	3	25	
21:30	0.105	3	25		4.42	10	10	40
Q_{ref}	11.655				19.07			

Warranty certificate

Length of warranty:

- Guarantee of the watertightness of the tank: 5 years
- Electrical System (Electronic and Heat Pump): 2 years

Replacement of a component or product can not in any case extend the initial warranty period.

DATE OF PURCHASE :

MODEL AND SERIAL NUMBER :

CLIENT NAME AND ADDRESS :

.....



English

Haier